

1600 SERIES

OPW 1600 Series Sight Flow Indicators are manufactured of quality materials and safety tested to assure long, dependable service at economical prices. Good for monitoring critical fluid flow, lubricant, coolant lines and sprinkler systems.

Benefits

- Economical prices
- Allows you to quickly verify flow, and monitor color and clarity in fluid lines
- 48 Hours delivery available to help minimize down time

Standard Features

- Brass construction
- Single and double window designs
- Sizes From 1/8"- 2"
- 125 psig Pressure Rating
- Available with or without rotor
- FNPT or BSPT connections

Physical Data

Maximum Pressure:	125 psig
Maximum Temperature:	200° F (93° C)
Seals:	Buna-N standard on all 1600 Series. Alternative seals available on request.
Glass Type:	Tempered Soda lime
Threads:	NPT or BSPT
Indicator:	ABS
Body:	Bronze

Ordering Information see page 16.

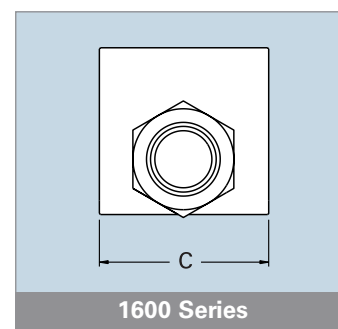
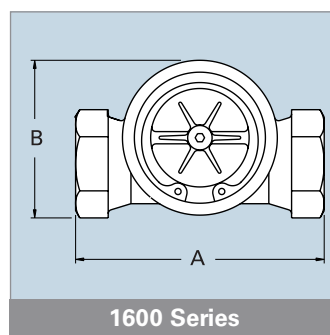

General Dimensions for 1600 Series

Size	1/8" - 3/8"	1/2" - 3/4"	1" - 1 1/4"	1 1/2" - 2"
A Overall Length	3 3/16"	3 13/16"	4 3/8"	4 5/8"
B Overall Height	2 1/8"	2 7/16"	3 1/8"	4"
C Overall Width	2 7/32"	2 7/16"	3"	3 13/16"

