



Liberty Overfill Prevention Systems

Security During Loading and Unloading Procedures

The OPWFTG Civacon Liberty

The OPWFTG Civacon Liberty overfill prevention system is designed for tank trucks, tank-truck loading stations (for top and bottom loading), storage depots and service stations. In the event of a possible overfill situation sensed by the Liberty sensors, the Liberty rack monitors output relay will send a signal to a terminal automation system, control valve, or pump, to shutdown the loading operation.

The Liberty

The Liberty failsafe and self-checking electronic sensors are available as 2-wire Thermistor, 2-wire quick start Optic, or 5-wire Optic. The Liberty on-board control monitors, with diagnostic display, offer 2-wire and 5-wire optic sensor compatibility with all other brands of rack monitors.



The ROM

The ROM on-board system combines overfill with retain feature of detecting presence of liquid in a compartment prior to loading. All on-board monitors can also be used as stand-alone truck system to close down tank-truck bottom valves in case of an overfull situation. The Liberty system conforms to Atex, Cenelec, and EN standards.

Ordering Specifications

OPW Liberty Overfill Prevention Systems

8500E	8-Channel thermistor and 12-Channel optic monitor with diagnostic display and infrared by-pass switch. Including ground verification.
-------	---

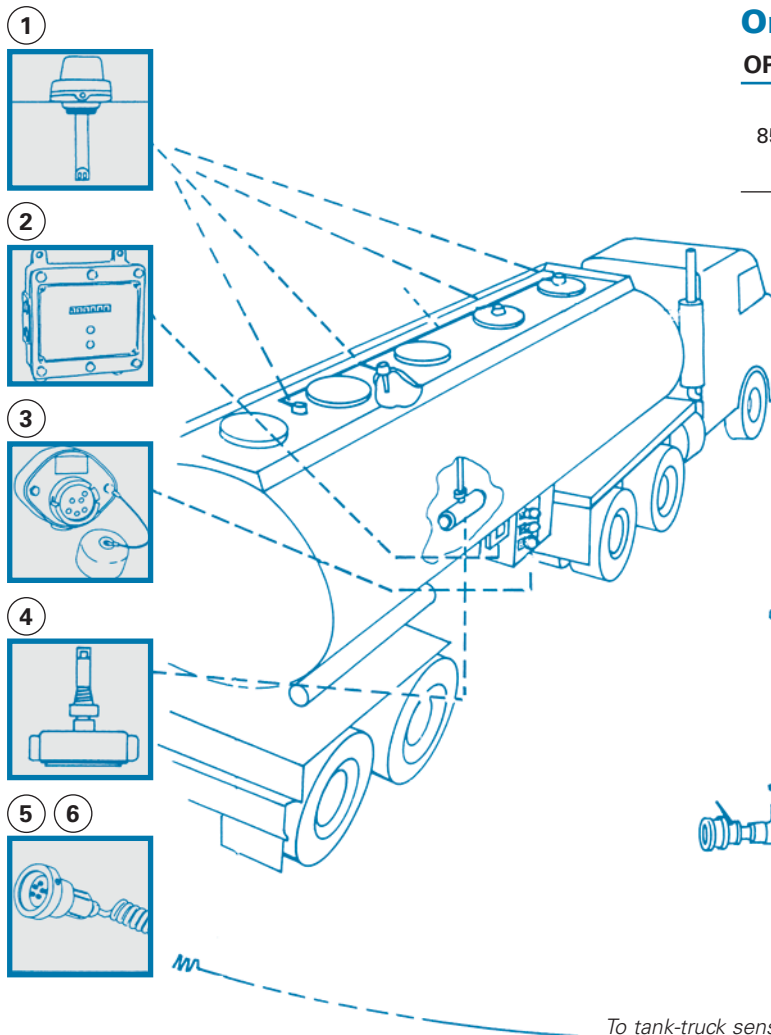

Trailer Equipment List

- 1 | Sensor(s): (One Per Compartment) Plus Sensor Cable
- 2 | On-board Control Monitor / ROM
- 3 | Rack-Compatible Socket(s)
- 4 | Retain Bottom Sensor

Loading Rack Equipment

- 5 | Rack Monitor
- 6 | Connecting Plug
- 7 | Plug/Monitor Cord Set

